

**Horizontal baby changing station**



- Made of stainless steel.
- Resistance and durability.
- The all-metal construction is designed to withstand heavy use and is ideal for unattended areas.
- Compact, wall mounted, folding design.
- Stylish, brushed stainless steel finish.
- Vandal-proof and resistant to graffiti.
- Exceptional fire resistance.
- Full compliance with the latest safety standard BS EN 12221:2008.

**TECHNICAL DETAILS**

- Designed to withstand static loads of 100 Kg. Intended for use for children up to a maximum weight of 15 Kg.
- Dimensions: closed 760 x 650x 165 (mm) – open 760 x 650x 615 (mm).
- Enhanced system – hinge of double hydro pneumatic damper.
- Gas locking mechanism.

**SUGGESTED TEXT FOR PRESCRIPTION**

VELTIA or similar, horizontal baby changing station, wall-mounted, made of stainless steel, brushed finish, folding design with enhanced system of double hydro pneumatic damper hinge and gas locking mechanism. Dimensions: closed 760 x 650x 165 (mm) – open 760 x 650x 615 (mm).

**TECHNICAL DRAWING**

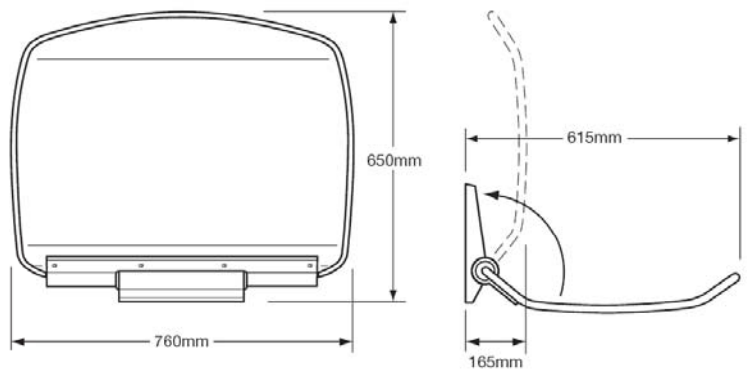

Related Products



09208



09207



09102.S



12001.S